

P.O. Box 2176  
Splendora, Texas 77372



Phone – 713-819-5099

Fax – 832-553-7948

## TABLE OF CONTENTS

1. Coupling
2. Safety Edge
3. Ball Screw
4. End Mounting Supports
5. Gear Motor Drive
6. Motor
7. Electrical Box
8. Boron Spec
9. Lead Spec
10. Calculations

# COUPLING



# Model EK2 Zero Backlash Elastomer Insert Coupling

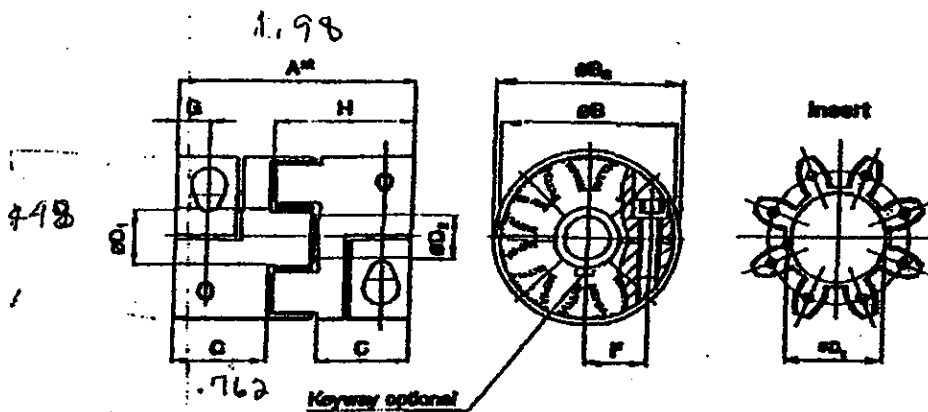

- Features:**
- Zero Backlash
  - Compensates for Misalignment
  - Torsionally Stiff
  - Absorbs Vibrations
  - Electrically Insulated

**Material:**  
Clamping Hub: Aluminum  
Elastomer Hub: Polyurethane  
Type A: Shore Value SH 88 A (standard)  
Type B: Shore Value SH 84 D  
(Shore Value SH 80 A also available for higher vibration dampening)

**Speeds:**  
Up to 4000 rpm standard.  
Over 4000 rpm with optional balanced version.

**Special Design:**  
Available upon request.

**Technical information:**

Size	Type (Elastomer)	Rated Torque Nm	Peak Torque Nm	Overall length mm	Outer Diameter	Outer diameter (optional)	Fl length	Bore Range (inch available)	Inner diameter (mm)	DM (DIN) mounting screw	Reference torque of the mounting screw	Drilling diameter (mm)	Drilling	Hub length	Mounting of hub	Approx. weight in kg	Static torsional stiffness (Nm/deg)	Inertial mass (kg)	Dynamic (optional) (kg)	Max. Speed (rpm)	Max. Torque (Nm)
20	A	17	24	85	44.5	25	18	M5	8	15	8.5	39	0.04	0.15	800	0.08	1	±1.2			
	B	21	42	85	44.5	25	18	M5	8	15	8.5	39	0.04	0.15	2900	0.08	0.8	±1.2			
60	A	60	120	78	57	30	27	M6	15	20	10	46	0.18	0.35	2065	0.1	1	±1.5			
	B	75	150	78	57	30	27	M6	15	20	10	46	0.18	0.35	3000	0.08	0.8	±1.5			
150	A	160	320	80	66	35	38	M8	40	24	12	62.5	0.40	0.6	3440	0.12	1	±1.8			
	B	200	400	80	66	35	38	M8	40	24	12	62.5	0.40	0.6	8480	0.1	0.8	±1.8			
300	A	325	650	114	82	45	46	M10	60	28	15	68	1.2	1.15	7880	0.14	1	±1.8			
	B	405	810	114	82	45	46	M10	60	28	15	68	1.2	1.15	15840	0.12	0.8	±1.8			
450	A	450	900	120	102	50	48	M12	120	38	17.5	73	3.0	2	22260	0.16	1	±2			
	B	500	1120	120	102	50	48	M12	120	38	17.5	73	3.0	2	42360	0.14	0.8	±2			

**Selection Factors:**

**Temperature Factor - F<sub>T</sub>**

Temperature	Type A	Type B
-30°C to +30°C	1.0	1.0
+30°C to +60°C	1.2	1.1
+60°C to +90°C	1.4	1.3
+90°C to +120°C	1.7	1.5
+120°C to +150°C	2.0	1.8
+150°C to +180°C	2.5	2.4

**Load Factor - F<sub>L</sub>**

Uniform	1.0
Medium Shock	1.8
Dynamic Reversing	2.5

$$T_A = T_N \times F_T \times F_L \times F$$

T<sub>A</sub> - Adjusted torque  
T<sub>N</sub> - Nominal torque  
F - Selection Factors

**Cycle Factor - F<sub>C</sub>**

Cycle per hour	up to 120	120 to 240	over 240
Factor	1.0	1.8	upon request

**Maximum Torque Transmittable by Keyless Hub (as a function of bore size)**

Size	Ø10	Ø16	Ø20	Ø25	Ø30	Ø36	Ø42	Ø48	Ø54	Ø60	Ø66	Ø72	Ø78	Ø84	Ø90
20	20	42	42	42											
60	80	80	100	110	120	120									
150			120	160	180	200	220								
300				150	180	210	220	280							
450						300	340	380	410	480	520	580			

Maximum torque possible with key.

**Ordering Example:**

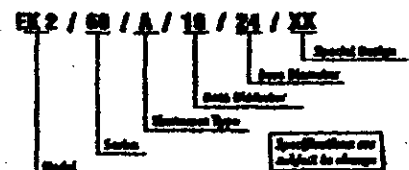

Specifications are subject to change

**SAFETY  
EDGE**

**MOUNTING INSTRUCTIONS FOR ELECTRICALLY OPERATED REVERSING EDGE**

DO NOT PAINT ANY PART OF THE REVERSING EDGE

**LEADING EDGE OF WOODEN DOORS - 2 METHODS :**

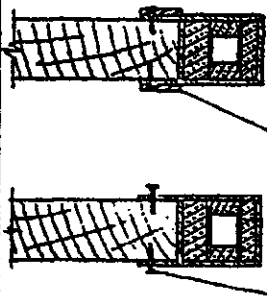

DRIVE SCREWS OR SCREWS - DECORATIVE STRIP - IF DESIRED - BY OTHERS

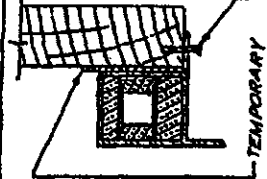

TEMPORARY SPACER STRIP OF CORRECT THICKNESS - BY OTHERS

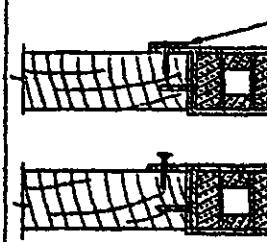

DRIVE SCREWS OR SCREWS - DECORATIVE STRIP - BY OTHERS

**"U" SHAPED REVERSING EDGE METHOD "A"**

- 1 CENTER REVERSING EDGE ON CENTER LINE OF DOOR, WITH CONNECTIONS AT PROPER END.
- 2 STAPLES, OR CARPET TACKS, ARE USED TO HOLD BOTH SIDE TABS IN PLACE.
- 3 STARTING ON CENTER LINE, & WORKING TOWARD BOTH ENDS, ON BOTH SIDES, SPACE TACKS ABOUT 2" APART. AVOID WRINKLING OF TABS.
- 4 IF DECORATIVE STRIPS ARE TO BE USED, USE EXTERIOR GRADE PLYWOOD - 1/4" X 1/2". ATTACH THESE STRIPS WITH #6 X 1" WOOD SCREWS, OR DRIVE SCREWS, SPACED ABOUT 8" APART.

- 1 TEMPORARILY ATTACH THE SPACER STRIP TO THE OUTSIDE FACE OF THE DOOR LEAF.
- 2 CENTER THE REVERSING EDGE ON CENTER LINE OF DOOR WITH CONNECTIONS AT THE PROPER END.
- 3 STAPLES, OR CARPET TACKS, ARE USED TO HOLD THE SIDE TAB IN PLACE.
- 4 TAKE PARTICULAR CARE TO KEEP THE EDGE OF THE TABS EXACTLY EVEN, ALONG ENTIRE LENGTH OF DOOR EDGE.
- 5 EXCESS TENSION ON TABS, AND UNEVEN TENSION, WILL CAUSE TABS TO WRINKLE.
- 6 USE #6 X 1" WOOD SCREWS, OR DRIVE SCREWS, SPACING THEM ABOUT 8" APART.
- 7 REMOVE SPACER STRIP AND CARPET TACKS.
- 8 FOLD REVERSING EDGE TO BOTTOM OF DOOR LEAF.
- 9 STARTING AT THE CENTER LINE, TACK, OR STAPLE, INSIDE TAB IN PLACE, ON 2" CENTERS.
- 10 USE EXTERIOR GRADE PLYWOOD - 1/4" X 1/2". ATTACH THIS STRIP WITH #6 X 1" WOOD SCREWS, OR DRIVE SCREWS, SPACED ABOUT 8" APART.
- 11 OTHERWISE, ATTACH TAB TO INTERIOR FACE OF DOOR LEAF WITH THESE SCREWS, TACKS,

**LEADING EDGE OF ROLLING CURTAIN DOORS :**

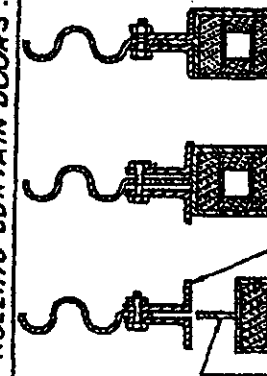

BASE ANGLES OF LEADING EDGE OF ROLLING CURTAIN DOOR. MOUNTING TAB

**"T" SHAPED REVERSING EDGE**

- 1 LOOSEN FASTENERS OF ANGLES OF LEADING EDGE OF ROLLING CURTAIN DOOR.
- 2 PLACE "T" MOUNTING TAB OF REVERSING EDGE BETWEEN ANGLES.
- 3 TAKE CARE NOT TO GET TAB TOO HIGH & PINCH THE HEAT SEALED PORTION, TO CAUSE PUNCTURE, OR PERMANENT CONTACT OF CONDUCTORS.
- 4 TIGHTEN ANGLES AT ELECTRICAL CONNECTIONS FIRST, THEN OPPOSITE END.
- 5 THEN WORK FROM CENTER, IN BOTH DIRECTIONS.

**CUT-AWAY VIEW OF REVERSING EDGE**

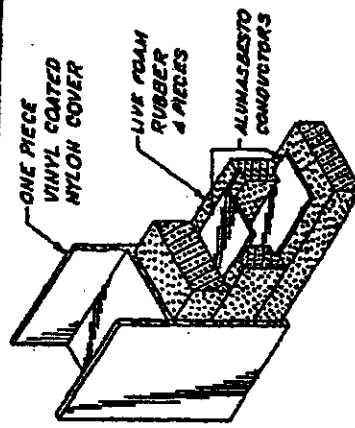

**REVERSING EDGE CONSTRUCTION "U" SHAPED CONFIGURATION SHOWN**

CONTACT STRIPS ARE ON OPPOSITE FACES OF THE CENTER CHANNEL. AN EVEN, LATERAL PRESSURE ON THE REVERSING EDGE MAKES AN ABSOLUTE CONTACT FOR A STOP AND REVERSING ACTION

**OPERATOR SPECIALTY CO., INC.**  
 CASHNOVIA, MI., 49318

DATE: 1-27-80  
 REVISED BY: JRS/B

**MOUNTING INSTRUCTIONS FOR ELECTRICALLY OPERATED REVERSING EDGE**

**ELECTRIC REVERSING EDGE 15A003**

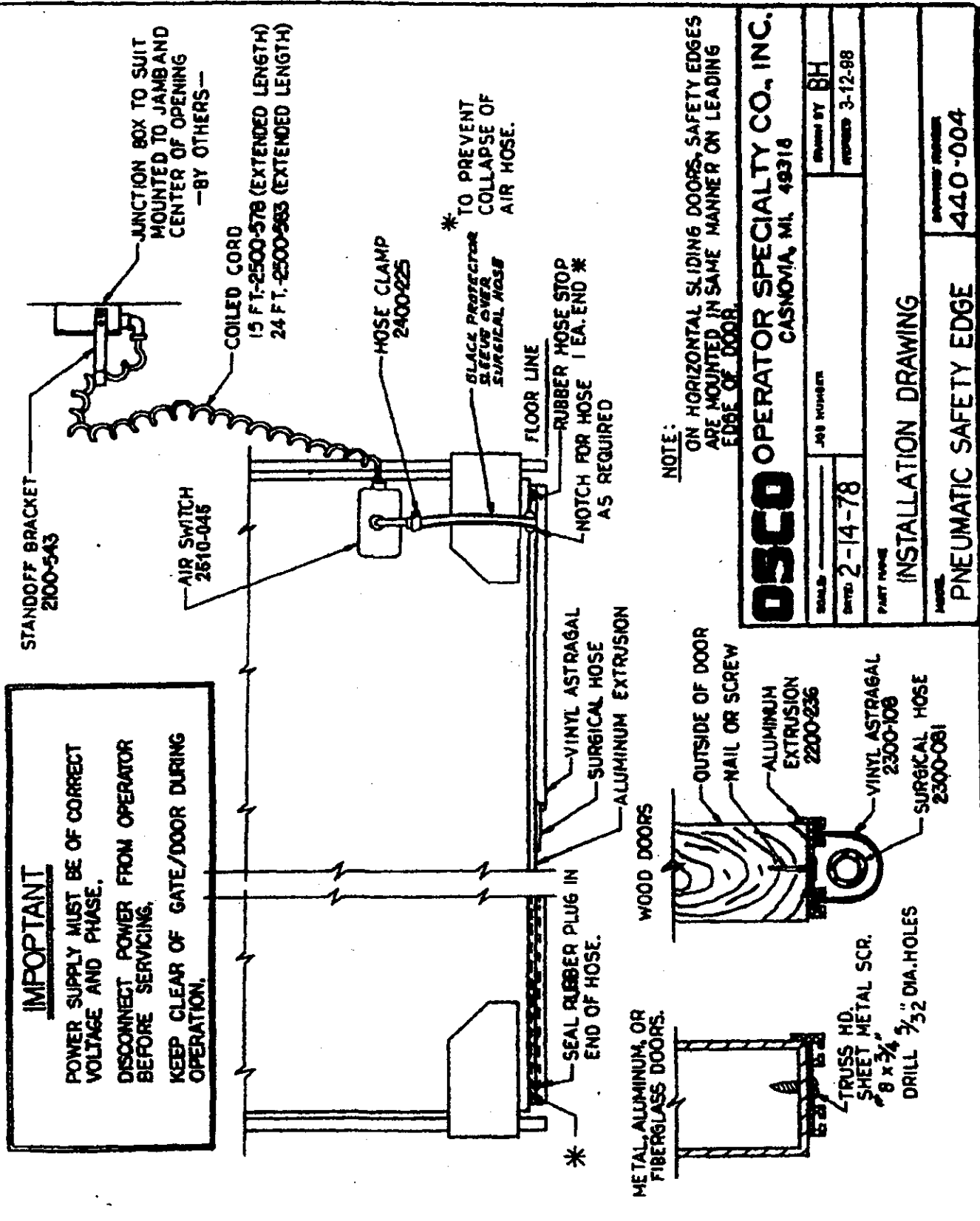

**BALL  
SCREW**

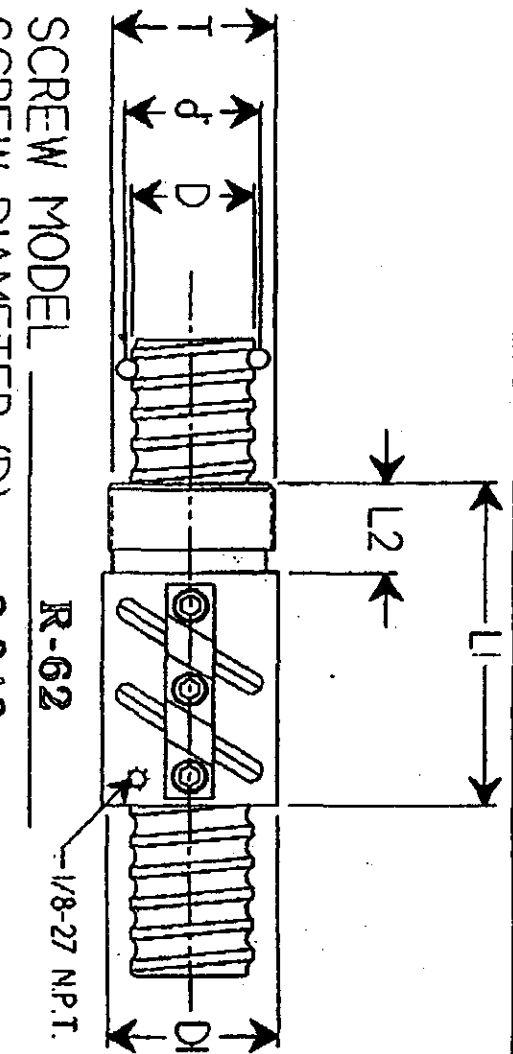

SCREW MODEL R-62

SCREW DIAMETER (D) 2.040

SCREW LEAD (PITCH) .500

BALL CIRCLE DIA. (D') 2.106

DIRECTION OF TURNS R.H.

# OF BALL CIRCUITS TWO

NUT LENGTH (L1) 6.375

THREAD LENGTH (L2) 1.500

THREAD SIZE (T) 3.000-12

NUT DIAMETER (DI) 3.250

TUBE WIDTH (W) 2.545

TUBE HEIGHT (H) 2.250

BALL SIZE .375

QTY. PER NUT 152 (AVG.)

OPERATING LOAD 18,000 LBS.

FOR  $1 \times 10^6$  INCHES LIFE.

MAX. STATIC LOAD 130,000 LBS.

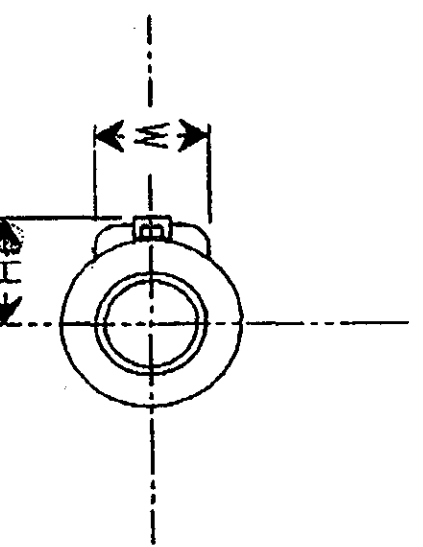

MOUNTING FLANGE DIAMETER 5.375

THICKNESS 1.531

NUMBER OF HOLES 8

HOLE DIA. .656

BOLT CIRCLE DIA. 4.250

WIPER KIT INFO: DIAMETER 2.690

THICKNESS .160

MATRL. NYLON BRUSH

R-62 BALL SCREW

TOLERANCES DRAWN BY SCALE DATE

XX +/- .020 BY APQ NONE 8/9/83

FINISH BLACK MATERIAL

FRAC. 1/32 REV. DRAW. NO. R-62

ANG 1 DEG

LINEAR WAY H LWHT...B, LWHTG

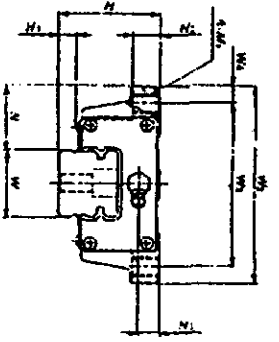

Model number	Weight		Dimensions of ball track (mm)						Dimensions of side rail (mm)									
	Ball weight kg	Track weight kg/m	H	H <sub>1</sub>	N	W <sub>1</sub>	W <sub>2</sub>	W <sub>3</sub>	W <sub>4</sub>	L <sub>1</sub>	L <sub>2</sub>	L <sub>3</sub>	L <sub>4</sub>	M <sub>1</sub>	M <sub>2</sub>	H <sub>1</sub>	H <sub>2</sub>	W
LWHT 15...B	0.22	1.47	24	4.5	16	47	28	4.5	46	30	44.6	69	M 5	7	4.3	13		
LWHT 20...B	0.48	2.36	30	5	21.6	63	53	5	82	40	57.2	96	M 6	10	5.5	20		
LWHTG 20	0.71	3.60	36	6.5	23.5	70	57	6.5	95	45	64.7	108	M 7	10	6.5	23		
LWHT 25...B	0.83	3.60	36	6.5	23.5	70	57	6.5	95	45	64.7	108	M 7	10	6.5	23		
LWHT 30...B	1.28	4.82	42	7	31	80	72	9	113	52	80.6	124	M 8	10	8	28		
LWHTG 30	1.69	6.85	48	8	32	100	92	9	139	52	106.6	150	M 10	10	8	28		
LWHT 35...B	1.79	6.85	48	8	32	100	92	9	139	52	106.6	150	M 10	10	8	28		
LWHTG 35	2.35	10.7	60	10	37.5	120	100	10	164	80	103.4	158	M 12	10	10	34		
LWHT 45...B	2.17	10.7	60	10	37.5	120	100	10	164	80	103.4	158	M 12	10	10	34		
LWHTG 45	4.24	15.6	70	13	42.8	140	118	12	190	95	132	194	M 14	17	14	45		
LWHT 55...B	5.30	15.6	70	13	42.8	140	118	12	190	95	132	194	M 14	17	14	45		
LWHTG 55	7.60	22.2	90	14	52.6	170	142	14	229	110	164	238	M 16	23	20	53		
LWHT 65...B	12.3	22.2	90	14	52.6	170	142	14	229	110	164	238	M 16	23	20	53		
LWHTG 65	17.8	32.2	110	16	62.6	200	162	16	281	110	194	288	M 18	30	30	63		

Note (1) Length of track, H, is given in Table 16 on page 84.  
 Note (2) Weight of ball track, W<sub>1</sub>, W<sub>2</sub>, and W<sub>3</sub> are given in Table 16 on page 84.  
 Note (3) Weight of side rail, W<sub>4</sub>, is given in Table 16 on page 84.  
 Note (4) Weight of ball track, W<sub>1</sub>, W<sub>2</sub>, and W<sub>3</sub> are given in Table 16 on page 84.  
 Note (5) Weight of side rail, W<sub>4</sub>, is given in Table 16 on page 84.  
 Note (6) Weight of ball track, W<sub>1</sub>, W<sub>2</sub>, and W<sub>3</sub> are given in Table 16 on page 84.  
 Note (7) Weight of side rail, W<sub>4</sub>, is given in Table 16 on page 84.

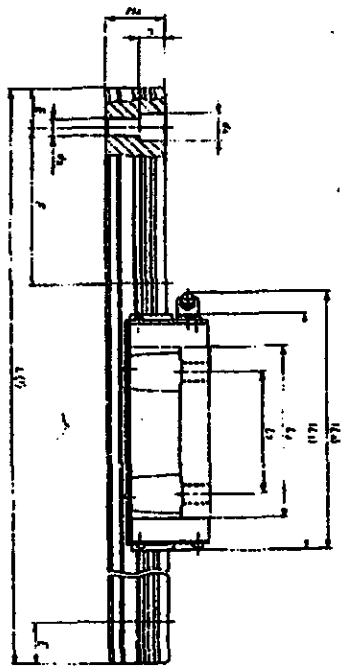

Model number	Dimensions of ball track (mm)		Dimensions of side rail (mm)		Ball weight (kg)		Track weight (kg/m)		Side rail weight (kg/m)		Total weight (kg/m)	
	H	H <sub>1</sub>	N	W <sub>1</sub>	W <sub>2</sub>	W <sub>3</sub>	W <sub>4</sub>	L <sub>1</sub>	L <sub>2</sub>	L <sub>3</sub>	L <sub>4</sub>	L <sub>5</sub>
LWHT 15...B	24	4.5	16	47	28	4.5	46	30	44.6	69	M 5	7
LWHT 20...B	30	5	21.6	63	53	5	82	40	57.2	96	M 6	10
LWHTG 20	36	6.5	23.5	70	57	6.5	95	45	64.7	108	M 7	10
LWHT 25...B	36	6.5	23.5	70	57	6.5	95	45	64.7	108	M 7	10
LWHT 30...B	42	7	31	80	72	9	113	52	80.6	124	M 8	10
LWHTG 30	48	8	32	100	92	9	139	52	106.6	150	M 10	10
LWHT 35...B	48	8	32	100	92	9	139	52	106.6	150	M 10	10
LWHTG 35	60	10	37.5	120	100	10	164	80	103.4	158	M 12	10
LWHT 45...B	60	10	37.5	120	100	10	164	80	103.4	158	M 12	10
LWHTG 45	70	13	42.8	140	118	12	190	95	132	194	M 14	17
LWHT 55...B	70	13	42.8	140	118	12	190	95	132	194	M 14	17
LWHTG 55	90	14	52.6	170	142	14	229	110	164	238	M 16	23
LWHT 65...B	90	14	52.6	170	142	14	229	110	164	238	M 16	23
LWHTG 65	110	16	62.6	200	162	16	281	110	194	288	M 18	30

kg=0.837N=2.205 lb  
 mm=0.039 inch

## ●Type

Four respective different types slide unit are available. On each type, normal and longer slide unit length are supplyable.

Table 1 Type and characteristics of LINEAR WAY H Series

Item	Type							
	LWH-B		LWHG		LWHT-B		LWHTG	
From								
Length of slide unit	Normal	Long	Normal	Long	Normal	Long	Normal	Long
Flange	With flange				Without flange			
Mounting method of slide unit	only from bottom		only from upper		only from upper			
Height	Normal				High		Normal	
Width	Normal				Narrow			
Load rating	Large	Very large	Large	Very large	Large	Very large	Large	Very large
Moment load	Good	Excellent	Good	Excellent	Good	Excellent	Good	Excellent

## ●Model Number

Model number of LINEAR WAY H Series consists of model code, size, part code, pre-load symbol, classification symbol and supplemental code.

When several special specifications are required, arrange the supplemental code alphabetically.

### Example of model number

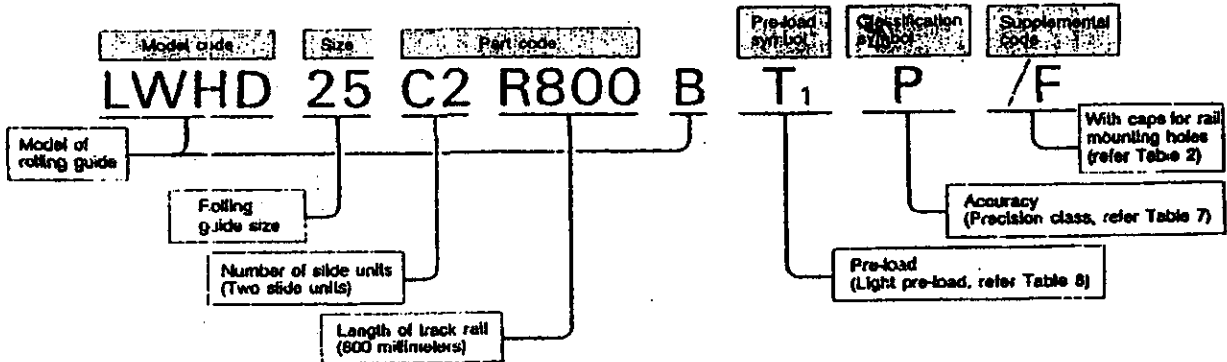

**END  
MOUNTING  
SUPPORTS**

# Bearing Block Installation Sheet

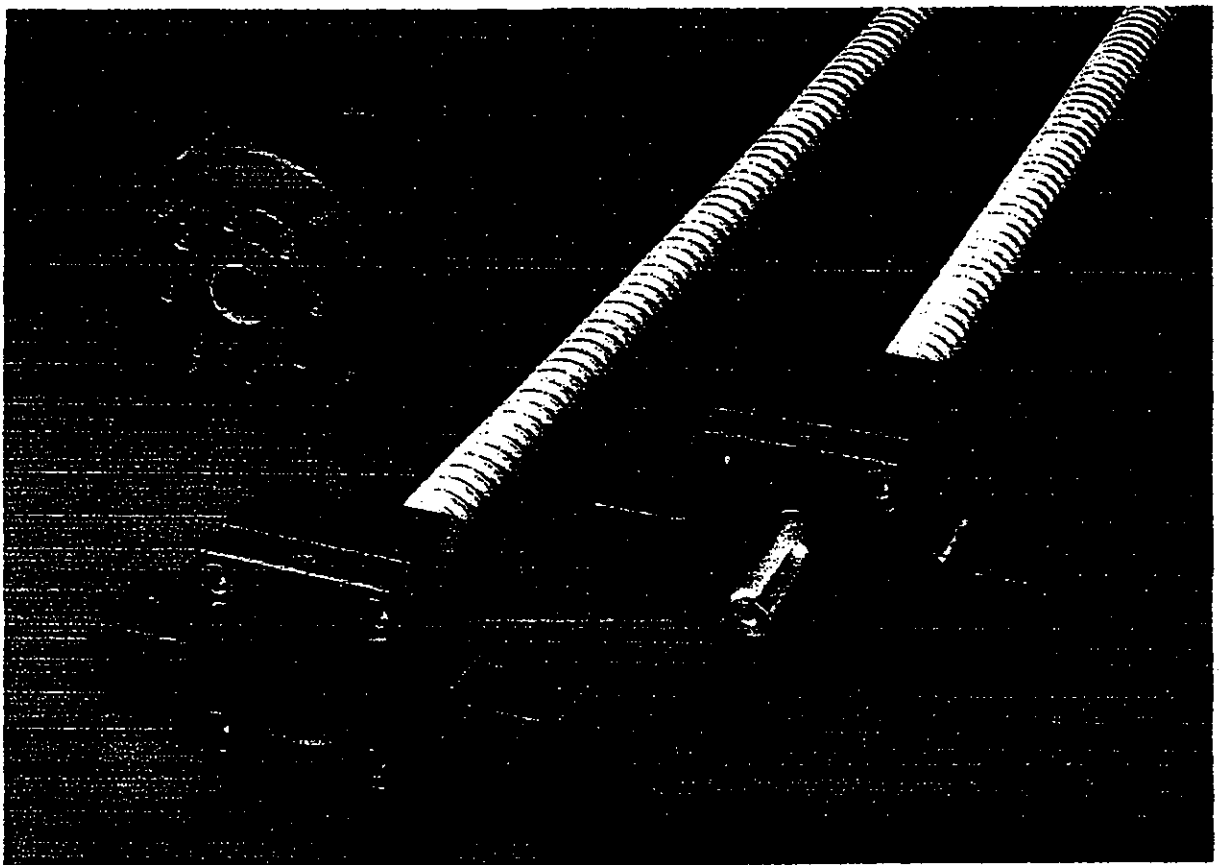

**W**arner Electric now has a line of pre-engineered ball screw support bearings for use with our ball bearing screws. Bearing supports are available as a base mount (for mounting to a surface) or flange mount (for mounting through the surface). Be sure to follow these directions carefully during installation to avoid damaging or reducing the life of the bearings.

**WARNER ELECTRIC®**

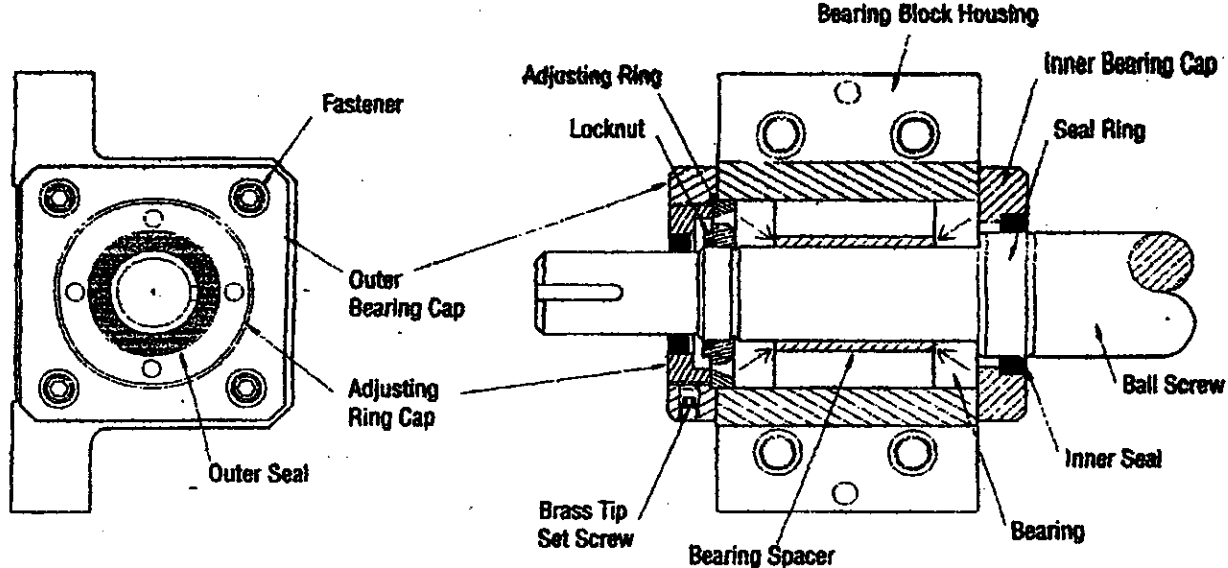

## Specifications

1. Remove the seal ring from inner bearing cap of the bearing block assembly. (The type "E" simple bearing blocks have a sealed radial bearing and do not require a seal ring.)
2. Remove the mounting fasteners from the outer bearing cap. Remove the bearing cap and adjusting ring.
3. Install the seal ring on ball screw journal by using an arbor to drive the seal ring against the ball screw shoulder.
4. Lubricate outside diameter of seal ring.
5. Install the bearing block assembly on the ball screw using an arbor to drive the inner part of the bearing/bearings only until the bearings are seated against the seal ring shoulder. Care should be taken not to damage locknut threads while installing bearings and that the bearings are not reversed. Do not change the orientation of the bearing faces during installation.
6. Install the locking nut and torque to the required specifications.
7. Install adjusting ring with the thin face toward the bearing race.
8. Loosen the inner bearing cap fasteners and align the inner seal on the seal ring and tighten in place.
9. Back off the two brass tip set screws in the outer bearing cap that are 90 degrees apart from each other. Rotate the adjusting ring cap counter clockwise two turns in order to ensure that the bearings will not be over tightened accidentally. Install the outer bearing cap and tighten both the inner and outer bearing cap fasteners securely.
10. Rotate the adjusting cap clockwise until it contacts the bearing. Adjust according to the following types of bearing blocks.

Type "E" & "F" bearing blocks: tighten the adjusting ring securely locking the bearing/bearings in place.

Type "H" bearing blocks: tighten the adjusting ring until there is no axial or radial play in the bearing housing, there will be a slight increase in drag on the bearings. **Note: Do not over tighten the bearings, this will increase the drag torque and shorten the bearing life of the assembly.**

Ball Screw Dia.	Torque (lb.ft.)
.625	10 - 20
.750	10 - 20
1.00	12-35
1.125	23-50
1.500	32-60
2.000	50-80
2.250	64-90
2.500	82-125
3.000	99-150

11. Snug the two brass tip set screws that are in the outer bearing cap 90 degrees apart from each other.

# 1.500" End Support

	End View	Type A	Type B	Type C
<b>Base</b>		<p>Type A feature single sealed ball bearing for radial support.</p>	<p>Type B feature back-to-back angular contact bearings for radial &amp; axial support.</p>	<p>Type C feature spaced angular contact for maximum radial and axial support.</p>
<b>Flange</b>				
<b>Cut-Off Flange</b>				

## TYPE C

**GEAR  
MOTOR  
DRIVE**

# Dimension Sheets

## HG OK. (OL.)

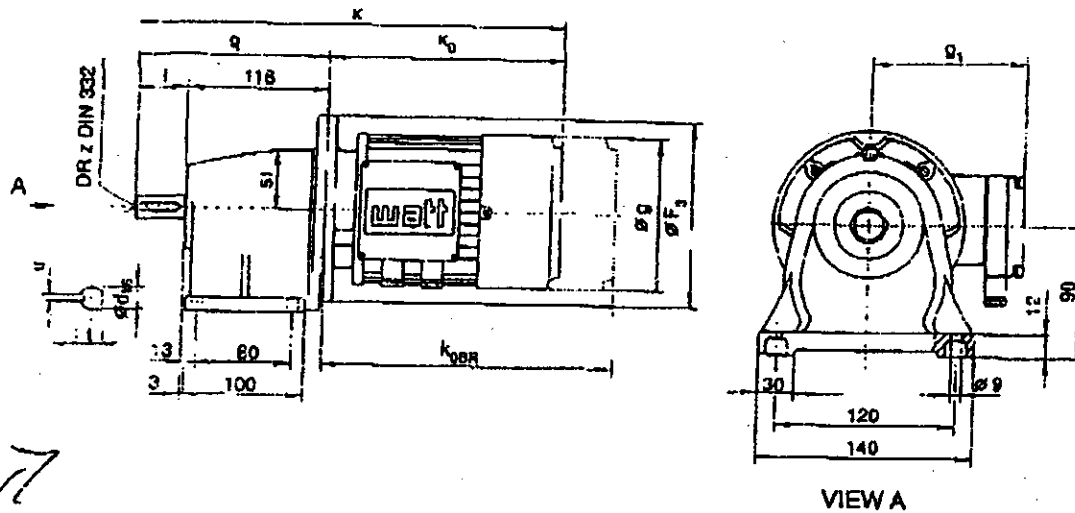

TYPE	k	Motor Dimensions						Flange Dimensions						Output Shaft				
		k <sub>D</sub>	k <sub>CBA</sub>	q	g <sub>1</sub>	F <sub>1</sub>	q	g <sub>F</sub>	D <sub>F</sub>	C <sub>F</sub>	g <sub>F</sub>	S <sub>F</sub>	l <sub>F</sub>	d	l	t	u	z
H. OKA,B,J 63K,N	340	162	227	118	121									16	40	16	5	M5
H. OKA,B,J 71K,N	358	201	248	132	128								20	40	22.5	6	M5	
H. OKB 80K,N	390	232	280	154	129	160	158	120	80	10	100	7	40					
H. OLA,J 63N	340	162	227	118	121			160	100	12	130	9	40					
H. OLA,J 71K,N	358	201	248	132	128								20	40	22.5	6	M6	
H. OLA,J 80K,N	390	232	280	154	129													

\* Indicates standard dimension in mm.  
 k dimensions are valid for standard output shafts.  
 Shafts up to and including 50mm diameter per ISO k6.

## HF OK. (OL.)

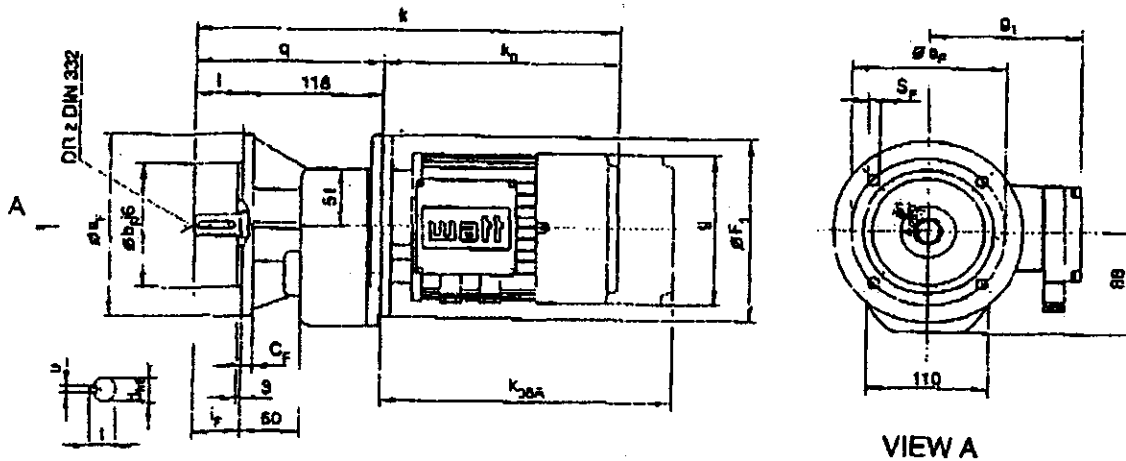

# Inline Helical Gearmotors - Selection Tables

Motor Power	Output Speed (rpm)	Service Factor $f_s$	Output Torque		Model Number	Total Weight lb/kg	Current Draw (Amp)		Dimen. Sheet Page No.	Price Code
			(lb-ft)	(Nm)			220V to 280V	380V to 460V		
1 HP 75 kw	58	1.5	90	122	HG 0N1 80N4	51/23	2.8	1.6	63	H2181
	59	2.1	89	121	HG 0Z1 80N4	55/25	2.8	1.6	64	H2180
	67	1.7	79	107	HG 0NA 80N4	51/23	2.8	1.6	63	H2181
	70	0.9	74	100	HG 0L1 80N4	37/17	2.8	1.6	62	H2183
	75	1.9	70	95	HG 0N1 80N4	51/23	2.8	1.6	63	H2181
	80	1	66	89	HG 0L1 80N4	37/17	2.8	1.6	62	H2183
	88	2.2	60	81	HG 0NA 80N4	51/23	2.8	1.6	63	H2181
	90	1.1	58	79	HG 0LA 80N4	37/17	2.8	1.6	62	H2183
	97	1.7	55	74	HG 0NC 80N4	51/23	2.8	1.6	63	H2182
	99	2.5	53	72	HG 0N1 80N4	51/23	2.8	1.6	63	H2181
	101	1.3	52	70	HG 0L1 80N4	37/17	2.8	1.6	62	H2183
	111	1.4	47	64	HG 0LA 80N4	37/17	2.8	1.6	62	H2183
	117	2.4	45	61	HG 0NC 80N4	51/23	2.8	1.6	63	H2182
	124	1.6	42	57	HG 0L1 80N4	37/17	2.8	1.6	62	H2183
	144	1.2	37	50	HG 0XB 80N4	35/16	2.8	1.6	62	H2184
	150	3.1	35	48	HG 0NC 80N4	51/23	2.8	1.6	63	H2182
	165	1.4	32	43	HG 0XB 80N4	35/16	2.8	1.6	62	H2184
	182	1.1	29	39	HG 0NE 80N4	40/18	2.8	1.6	82	H2185
	188	1.6	28	38	HG 0XB 80N4	35/16	2.8	1.6	62	H2184
	198	4.1	27	36	HG 0NC 80N4	51/23	2.8	1.6	63	H2182
228	1.7	23	31	HG 0NE 80N4	40/18	2.8	1.6	82	H2185	
* 237	2	22	30	HG 0XB 80N4	35/16	2.8	1.6	62	H2184	
252	5	21	28	HG 0NC 80N4	51/23	2.8	1.6	63	H2182	
276	2.4	19	26	HG 0NE 80N4	40/18	2.8	1.6	82	H2185	
291	2.5	18	24	HG 0XB 80N4	35/16	2.8	1.6	62	H2184	
353	3.1	15	20	HG 0NE 80N4	40/18	2.8	1.6	82	H2185	
466	4.1	11	15	HG 0NE 80N4	40/18	2.8	1.6	82	H2185	
593	5	9	12	HG 0NE 80N4	40/18	2.8	1.6	82	H2185	
1.5 HP 1.1 kw	1.2	1	5873	7963	HG 6SX 1HV 90S4	735/334	4	2.3	81	H2191
	1.4	1.1	5278	7156	HG 6SD 1HV 90S4	735/334	4	2.3	81	H2191
	1.6	1.3	4699	6371	HG 6SX 1HV 90S4	735/334	4	2.3	81	H2191
	1.7	1.3	4479	6072	HG 6SD 1HV 90S4	735/334	4	2.3	81	H2191
	1.9	1.6	3833	5197	HG 6SX 1HV 90S4	735/334	4	2.3	81	H2191
	2	1	3735	5064	HG 5ST 1HV 90S4	460/209	4	2.3	79	H2192
	2.1	1.7	3468	4702	HG 6SD 1HV 90S4	735/334	4	2.3	81	H2191
	2.4	2	3034	4114	HG 6SX 1HV 90S4	735/334	4	2.3	81	H2191
	2.4	1.2	3034	4114	HG 5SD 1HV 90S4	460/209	4	2.3	79	H2192
	2.6	1.3	2801	3798	HG 5ST 1HV 90S4	460/209	4	2.3	79	H2192
	2.7	2.2	2697	3657	HG 6SD 1HV 90S4	735/334	4	2.3	81	H2191
	3	1.5	2428	3292	HG 5SD 1HV 90S4	460/209	4	2.3	79	H2192

**MOTOR**

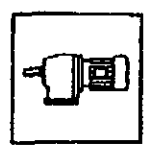
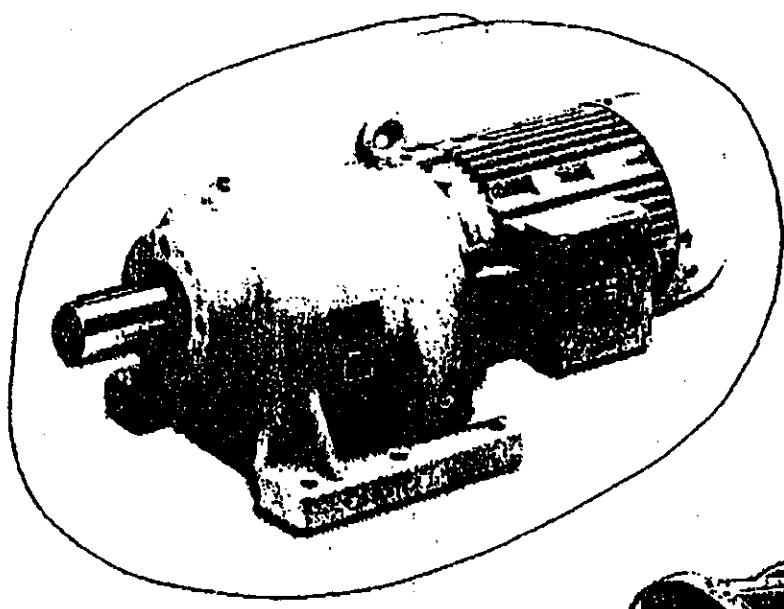

**HG**  
Foot Mounted

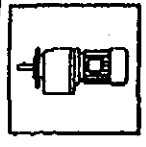

**HF**  
Flange Mounted

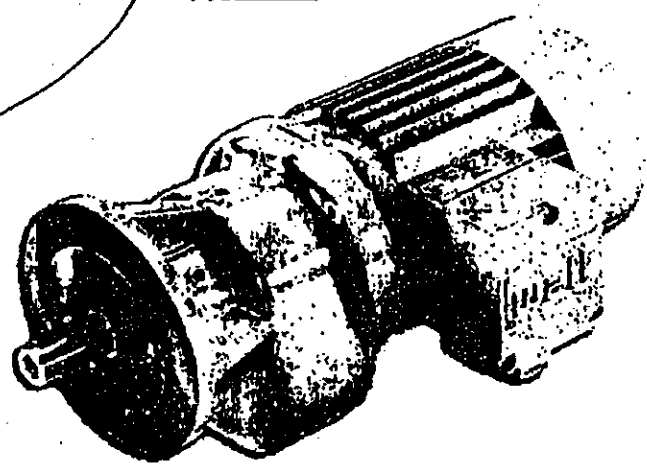

The WATT Inline Helical Gearmotor is one of the most versatile gearmotors available today. Literally thousands of ratios, speeds, sizes and output torques are available because of its unique modular design. Every gear unit is designed for continuous and long term duty under the most extreme conditions. The housings are designed to be as compact and robust as possible for maximum power and torque transmission. They are made of high-grade grey cast iron and incorporate oversize bearings for long life. The helical gears are produced on CNC gear cutting equipment and then case hardened and finished using the latest skive hobbing and honing technologies.

The WATT Modular Design allows the Inline Helical Gearmotor to be produced with either inch or metric shafts, and is assembled to a direct flange-mounted IEC motor. The WATT motor is an inverter duty, wide range multi-voltage motor, which can be installed virtually anywhere in the world. It is produced with oversize bearings and upgraded rotor materials for improved load bearing capacity and longer service life. A full line of motor brakes, electronic variable speed drive systems, and an extensive list of motor options are also available.

Please contact your DieQua representative for additional information.

# **ELECTRICAL BOX**